

Operator's manual

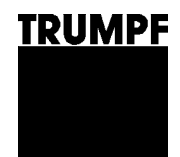

TruTool S 420 (1A2)

English



Contents

| | | |
|-----------|--|-----------|
| 1. | Safety | 3 |
| 1.1 | General safety information..... | 3 |
| 1.2 | Specific safety information..... | 3 |
| 2. | Description | 5 |
| 2.1 | Intended use | 6 |
| 2.2 | Technical data | 7 |
| 3. | Setting work | 8 |
| 3.1 | Selecting the blade | 8 |
| 3.2 | Setting the cutting clearance | 10 |
| | Cutting clearance..... | 11 |
| 4. | Operation | 12 |
| 4.1 | Working with the TruTool S 420 | 12 |
| 5. | Maintenance | 13 |
| 5.1 | Regrinding blades..... | 14 |
| | Moving cutter blade | 14 |
| | Fixed cutter blade | 14 |
| 5.2 | Changing the blade..... | 15 |
| | Turning over or replacing the moving cutter blade | 15 |
| | Turning over or replacing the fixed cutter blade | 15 |
| 5.3 | Supplying with power and guaranteeing lubrication | 16 |
| 5.4 | Replacing fins | 17 |
| 5.5 | Cleaning the strainer..... | 17 |
| 6. | Original accessories and wearing parts..... | 18 |

Guarantee

Spare parts list

Addresses

1. Safety

1.1 General safety information

- Before starting up the machine, read the operator's manual and the safety information (order no. 0373678) in their entirety and carefully follow the instructions given.
- Adhere to the safety regulations in accordance with DIN VDE, CEE, AFNOR and to the specific regulations of the country of operation.



Danger

Risk of fatal injury from electric shock

- When working with the machine do not touch any electrical lines. The machine is not insulated.
-



Warning

Risk of injury due to improper handling.

- Always detach the compressed air hose from the machine prior to maintenance work.
 - Check the compressed air hose, connection coupling, and machine for damage before each use.
 - Wear safety glasses, hearing protection, protective gloves and work shoes when working at the machine.
 - Only connect compressed air when the machine is switched off.
 - Always lay the compressed air hose away from the back of the machine.
-

1.2 Specific safety information



Warning

Risk of injury to hands.

- Do not reach into the processing line with your hands.
 - Use both hands to hold the machine.
-



Warning

Risk of injury from hot and sharp chips!

- Use chip deflector.
-

**Warning****Risk of injury due to improper handling.**

- Make sure the machine is always in a stable position when operating it.
 - Never touch the tool while the machine is running.
 - Always operate the machine away from your body.
 - Do not operate the machine above your head.
-

**Caution****Damage to property due to improper handling.****The machine will be damaged or destroyed.**

- Always position the compressed air hose leading away from the machine, at back of the machine. Do not pull the cable over sharp edges.
 - Have servicing and inspections of hand-held compressed air tools carried out by a qualified technician. Only use original TRUMPF accessories.
-

2. Description

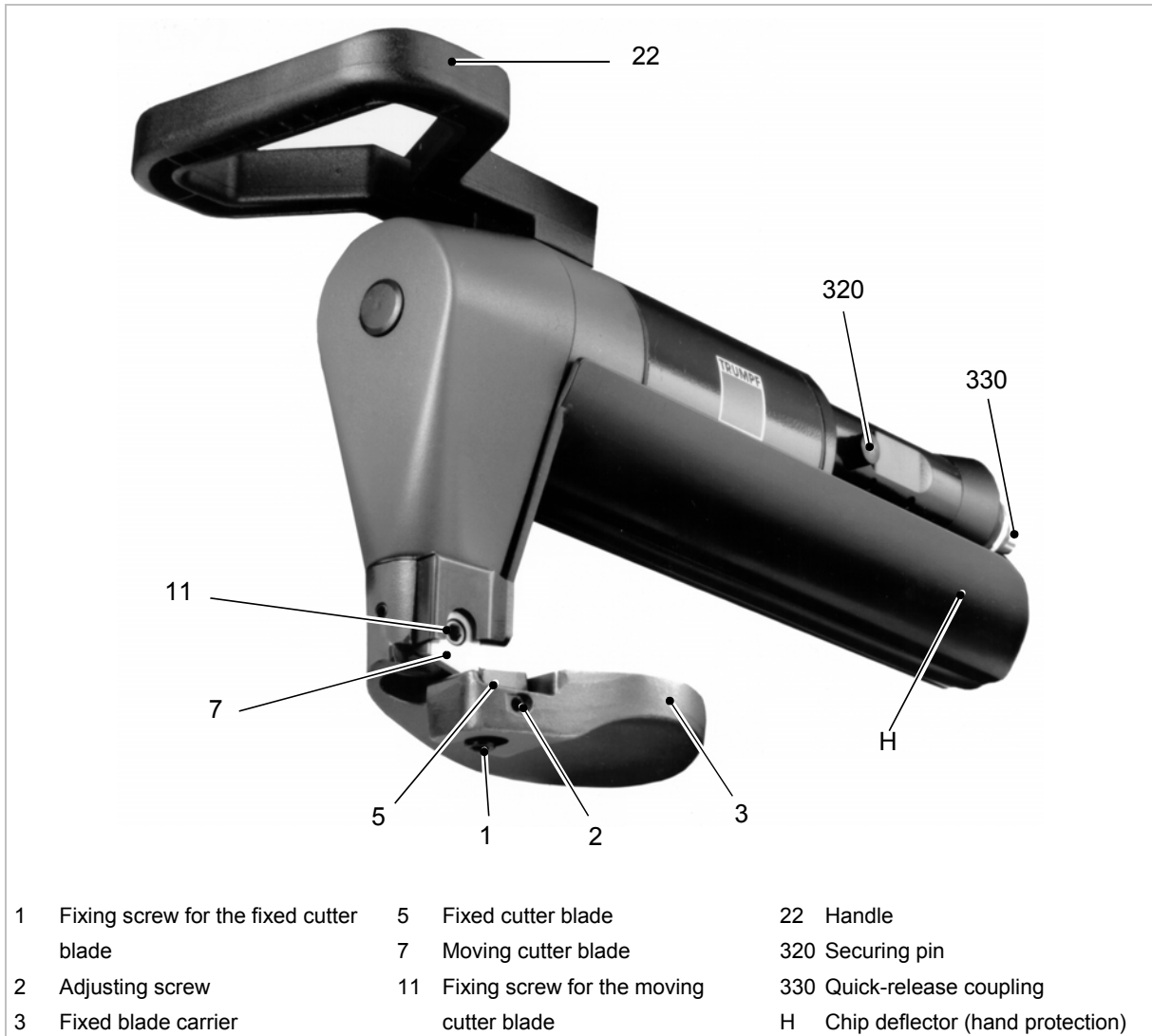

TruTool S 420 Shears

Fig. 10239

2.1 Intended use



Warning

Risk of injury

- Only use the machine for work and materials as described under "Intended use."
-

The TRUMPF TruTool S 420 shears are a compressed air tool used for the following applications:

- Chip-free slitting and edge-planing of plate-shaped workpieces made of steel, aluminum, plastic etc.
- Production of straight or curved exterior and interior cutouts.
- Cutting along scribed lines.
- Slitting of coils.

2.2 Technical data

| | Other countries | USA |
|---|-------------------------|----------------------|
| | Value | Value |
| Max. material thickness: | | |
| • Steel 400 N/mm ² | 4.2 mm | 0.165 in |
| • Steel 600 N/mm ² | 3.0 mm | 0.118 in |
| • Steel 800 N/mm ² | 2.0 mm | 0.079 in |
| • Aluminum 250 N/mm ² | 5.0 mm | 0.197 in |
| Working speed | 4-5 m/min | 13.123-16.404 ft/min |
| Smallest radius with curved cutouts | 25 mm | 0.984 in |
| Starting hole diameter for die | Min. 60 mm | 2.362 in |
| Cutting track width | 11 mm | 0.433 in |
| Nominal power consumption | 1100 W | 1100 W |
| Stroke rate at complete load | 530/min | 530/min |
| Weight | 6.3 kg | 13.899 lbs |
| Max. operating pressure (flow pressure) | 6 bar | 87 psi |
| Air consumption at 6 bar | 1.7 m ³ /min | 60.036 cubic ft/min |
| Inside diameter of the compressed air hose | 18 mm | 0.7 in (3/4") |

Table 1

| Vibration | Measured values in accordance with EN 50144 |
|--------------------|---|
| Hand-arm vibration | ≤2.5 m/s ² |

Table 2

Values were measured while cutting sheet steel 400 N/mm² with max. material thickness.

| Noise emissions | Measured values in accordance with EN 50144 |
|--|---|
| A-rated sound level L _{WA} | 86 dB |
| A-rated acoustic power level at the work place L _{PA} | 94 dB |

Table 3

The noise emission values given are the sum of the measured values and the corresponding uncertainties. They represent an upper limit of the possible measured values.

3. Setting work

3.1 Selecting the blade



Caution

Damage to property due to the wrong blade selection!

The cutting quality will be severely impaired and the individual tools overloaded.

- Use suitable tools only.

The blade is notable for the following points:

- Moving cutter blade (upper blade) and fixed cutter blade (lower blade) are identical in shape and can be used interchangeably (above or below).
- All blades have two cutting edges.
- They are non-regrindable "2-way multi-edge, throw-away cutters".

Note

Different blade types can be selected for the machining process, depending on the thickness or the tensile strength of the workpiece (see Table 4, Pg.9)

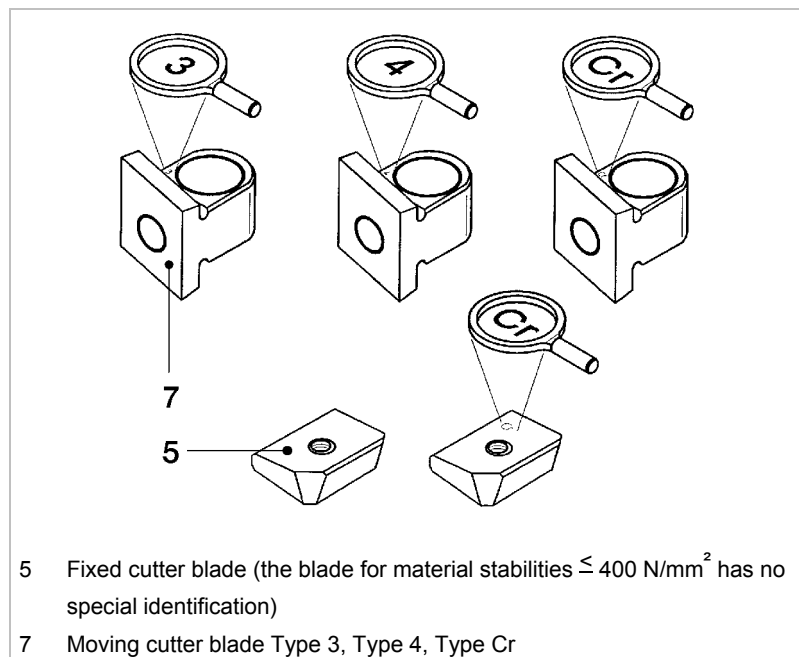

Blade with type identification

Fig. 10098

Note

Standard blades for materials with a tensile strength of $\leq 400 \text{ N/mm}^2$ have no special identification marking. Chromium steel blades are marked with "Cr".



| Blade | Type | Material thickness range in mm | Material type and tensile strength | Order No. | |
|---------------------|--------------|--------------------------------|---|-----------|--------|
| Moving cutter blade | 3 | 3.0-4.0 | Aluminum 250 N/mm ² and Mild steel 400 N/mm ² | 140451 | |
| | 4 | 3.0-4.2 | | | |
| Fixed cutter blade | ¹ | 1.0 - 4.2 | | 140451 | |
| Moving cutter blade | 3 | (1.0 - 2.8) ² | Stainless steel 600 N/mm ² | 140451 | |
| | Cr | 1.0 - 2.8 | | 140452 | |
| Fixed cutter blade | ¹ | (1.0 - 2.8) ² | | | |
| | Cr | 1.0 - 2.8 | | | 140452 |
| Moving cutter blade | 3 | (1.0-2.0) | Stainless steel 800 N/mm ² | | |
| | Cr | 1.0-2.0 | | | |
| Fixed cutter blade | ¹ | (1.0-2.0) | | | |
| | Cr | 1.0-2.0 | | | |

Table 4

¹The fixed cutter blade the blade for material stabilities of up to 400 N/mm² has no special type identification)

² Utilisation is possible, though this will result in advanced wearing

3.2 Setting the cutting clearance

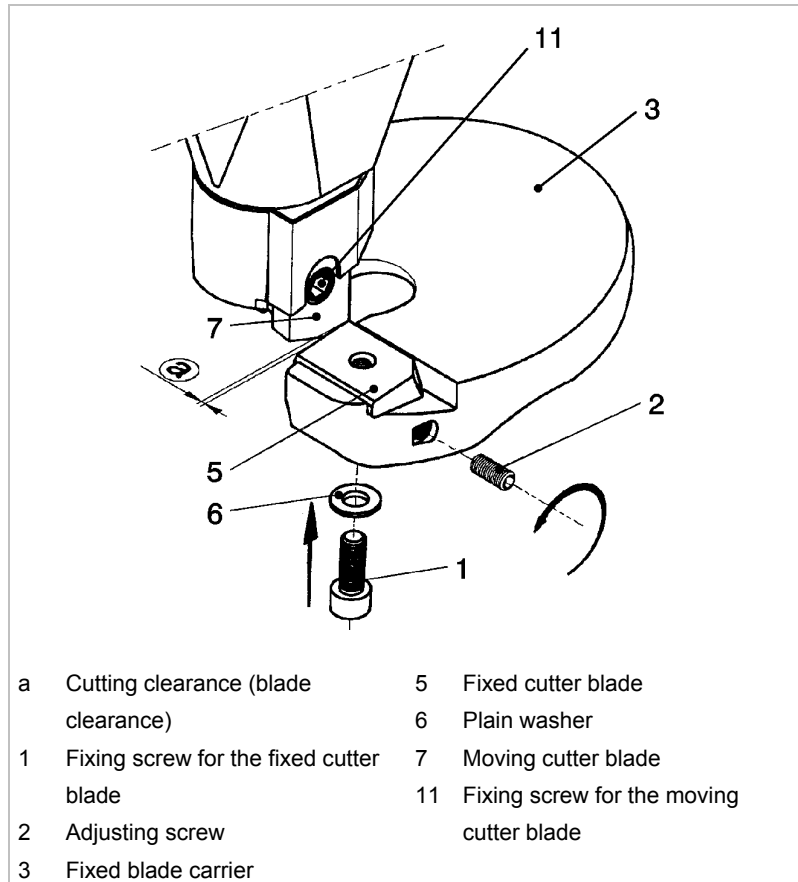

Fig. 10100

1. Push the lever several times until the moving cutter blade (7) has reached the lower dead point.
2. Detach the compressed air hose from the machine.
3. Screw on the fixed cutter blade (5) loosely with the fixing screw (1).
4. Using the adjusting screw (2), set the fixed cutter blade (5) to the desired cutting clearance.
5. Check the cutting clearance with a feeler gauge.
6. Tighten the fixing screw (1).
7. Tighten the adjusting screw (2) slightly.



Cutting clearance

The cutting clearance must amount to 0.2x of the material thickness to be cut.

Examples:

| Material thickness s in mm | Cutting clearance (blade clearance) a in mm |
|-------------------------------|--|
| 1.5 | 0.3 |
| 2.0 | 0.4 |
| 3.0 | 0.6 |
| 4.0 | 0.8 |

Table 5



4. Operation

4.1 Working with the TruTool S 420



Warning

Risk of injury due to improper handling.

- Make sure the machine is always in a stable position when operating it.
- Never touch the tool while the machine is running.
- Always operate the machine away from your body.

Switching on the TruTool S 420

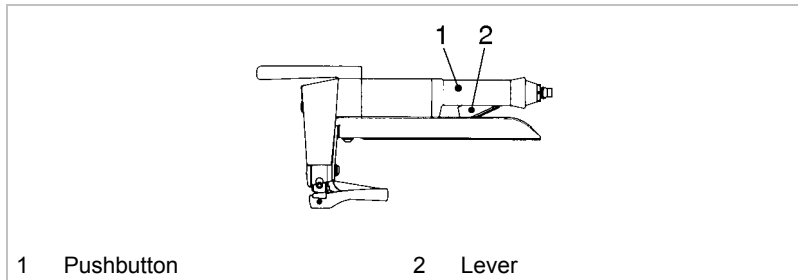

Fig. 10241

Continuous operation

1. Press the pushbutton (1).
2. Press the lever (2) against the motor housing.
3. Release the pushbutton.

Working with the TruTool S 420

1. Do not move the machine towards the workpiece until full speed has been reached.
2. Machine the material.
 - Move the machine forward at an angle of 80 to 90° to the sheet surface.

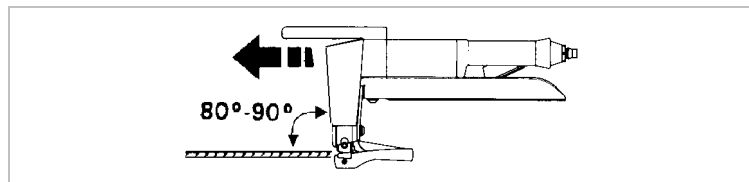

Fig. 10250

Cutting radiuses

- 3 Do not tilt the machine.
- 4 Proceed with a low feed rate.

Cutting on the edge

- 5 Cut in upside-down position,
- 6 The fixed blade carrier faces upwards.

Switching off the TruTool S 420

- Release the lever (2).

The lever springs back to the initial position and the compressed air is interrupted.

5. Maintenance



Warning

Risk of injury due to uncontrolled machine movements.

- Detach the compressed air hose when changing tools and before performing any maintenance work on the machine.



Warning

Risk of injury due to incorrect repair work!

Machine does not work properly.

- Repair work may only be carried out by a qualified technician.



Caution

Damage to property caused by blunt tools!

Machine overload.

- Check the cutting edge of the cutting tool hourly for wear. Sharp cutting tools provide good cutting performance and are easier on the machine. Replace punches promptly.

| Maintenance point | Procedure and interval | Recommended lubricant | Lubricant Order No. |
|-----------------------------|---|-------------------------|---------------------|
| Moving cutter blade guide | Lubricate every 20 hours of operation. | Lubricating grease "S1" | 0121486 |
| Gearbox and gear head | Have a qualified technician relubricate or replace the lubricating grease every 300 operating hours. | Lubricating grease "G1" | 0139440 |
| Oil mist lubrication device | Maintain daily in accordance with the manufacturer's specifications (see "Supplying with power and guaranteeing lubrication", p. 16). | - | - |
| Fins | Have these checked and replaced if necessary by a qualified specialist. | - | - |
| Strainer | Clean every 10 operating hours or when there is a decline in performance. | - | - |

Maintenance table

Table 6

5.1 Regrinding blades

Moving cutter blade

The moving cutter blade must not be reground.

Fixed cutter blade

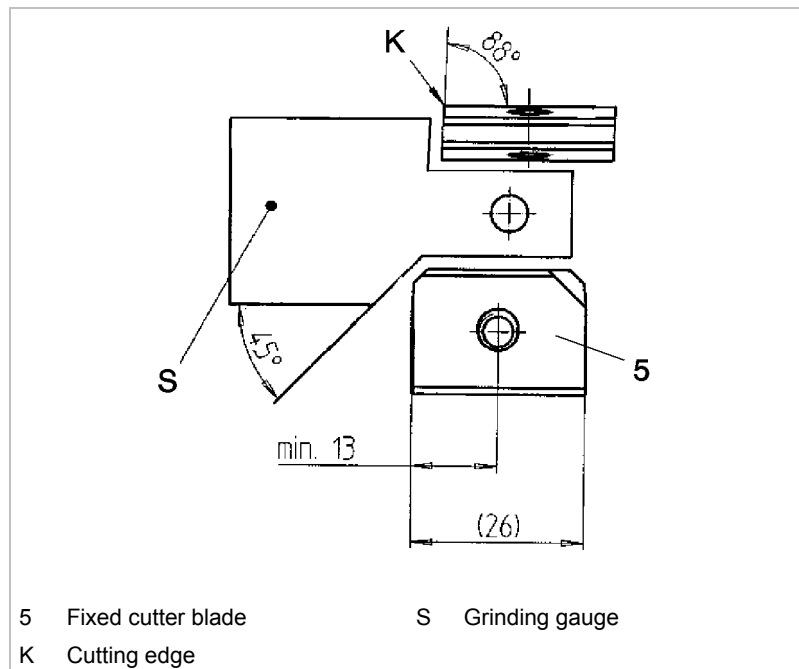

Fig. 10101

The fixed cutter blade can be reground by a total of approx. 2 mm (2x1 mm).

- Regrind the cutting edge in accordance with the diagram, making sure that it is well-cooled during the process.
- Lightly apply fine-grained oil stone to the cutting edge.
- Observe a minimum length of 26 mm or 13 mm. Shorter punches must be replaced (risk of collision).

5.2 Changing the blade

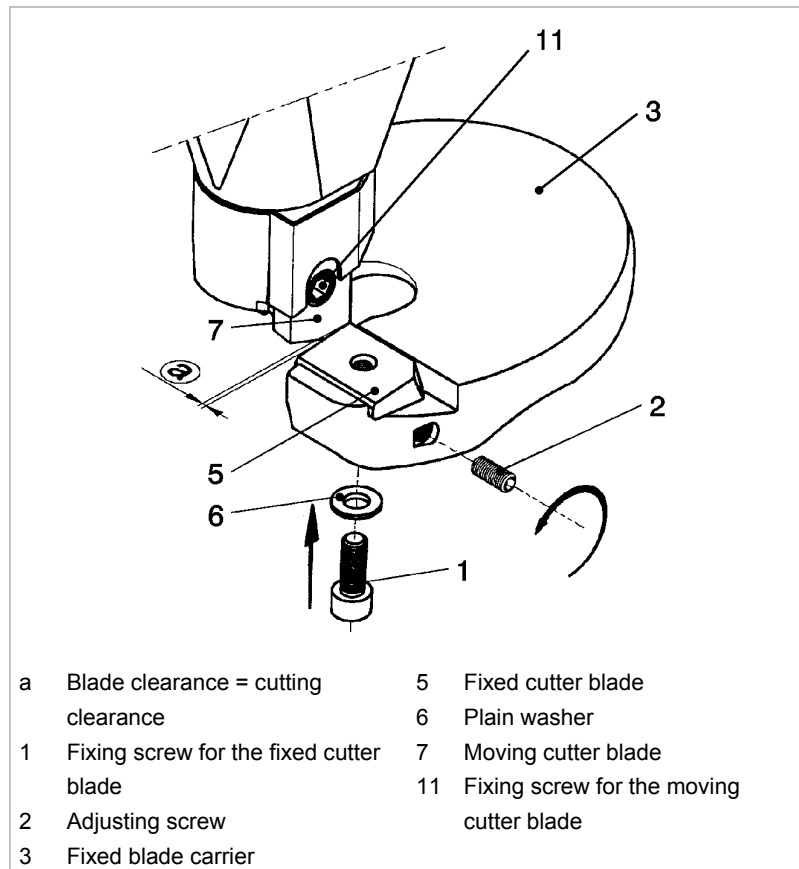

Fig. 10100

Turning over or replacing the moving cutter blade

1. Undo the fixing screw (11).
2. Rotate the moving cutter blade (7) by 180° and remount it (or mount a new blade).
3. Screw in the fixing screw (11) and tighten it.

Turning over or replacing the fixed cutter blade

1. Undo the fixing screw (1).
2. Rotate the fixed cutter blade (5) by 180° and retighten the fixing screw (1).

Note

Observe cutting clearance.

5.3 Supplying with power and guaranteeing lubrication



Caution

Damage to property due to improper handling.

Failure of the compressed air motor.

- Do not exceed the maximum operating pressure.
- Regularly lubricate the compressed air motor. Install an oil mist lubrication device into the compressed air line.

Supplying compressed air

Prerequisite

- Pressure regulating valve and connecting thread are set up correctly.

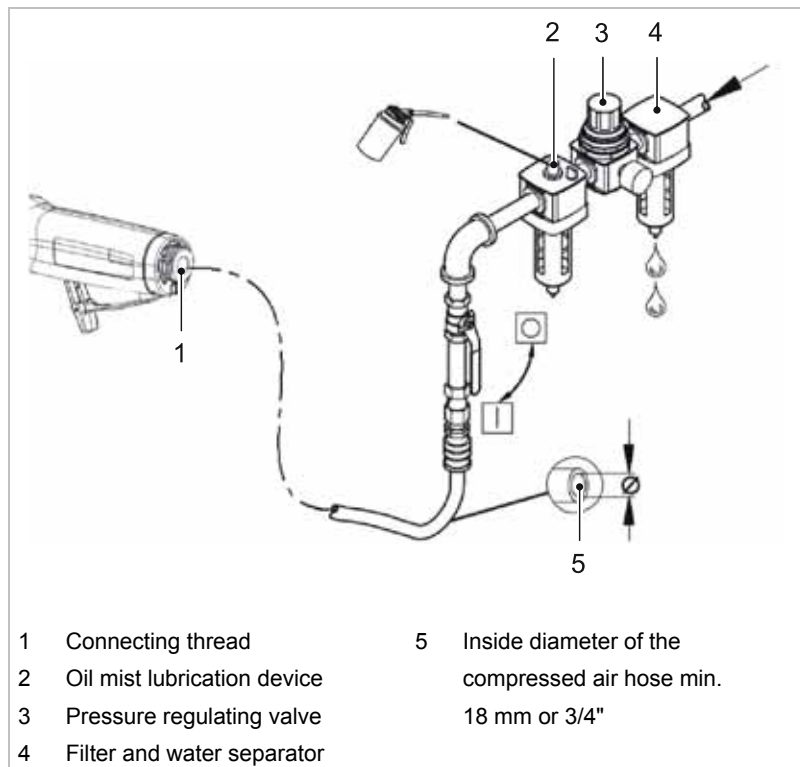

Compressed air supply

Fig. 52385

1. Install the filter and water separator (4).
2. Drain/check the water separator daily.

Note

- To ensure a supply of compressed air, the tube cross-sections in the entire line system must be twice to three times the size of the inside diameter of the compressed air hose.
- Secure the compressed air hose against undesired movements using a compressed air safety device.

**Checking the oil supply**

- Hold a piece of paper in front of the exhaust air vent in the motor housing when the machine is running.

The oil supply is sufficient when oil spots appear.

5.4 Replacing fins

Worn fins decrease machine performance.

- Have the fin set checked and replaced as needed by a qualified technician.

Note

Only use original replacement parts and observe the information on the rating plate.

5.5 Cleaning the strainer

Dirty strainers decrease machine performance. Clean the strainer, which is screwed into the connection piece (328), every 10 operating hours. (For an illustration of the positions 328 (= "connection") and 329 (= "nipple"), see the replacement parts list.)

1. Unscrew the strainer and blow it out with compressed air.
2. Screw the strainer back in.

6. Original accessories and wearing parts

| TruTool S 420 | Supplied original accessories | Wearing parts | Options | Order No. |
|--|-------------------------------|---------------|---------|-----------|
| Die for 1-3 mm (type 3) | | + | | 106149 |
| Die for 3-4.2 mm (type 4) | + | + | | 103496 |
| Moving cutter blade for high-tensile sheets (type Cr) | | + | | 107623 |
| Fixed cutter blade for 1-4.2 mm | + | + | | 103498 |
| Fixed cutter blade for high-tensile sheets (type Cr) | | + | | 107621 |
| Set of tools (moving cutter blade and fixed cutter blade, mounted) | | | | |
| Quick-release coupling (machine-side part) | + | | | 114094 |
| Quick-release coupling (hose-side part) | + | | | 114095 |
| Handle | + | | | 094664 |
| Allen key DIN 911-5 | + | | | 067857 |
| Allen key DIN 911-6 | + | | | 067865 |
| Allen key DIN 911-2.5 | + | | | 067822 |
| Cap screws M8x20 for fastening the handle DIN 912 | + | | | 016012 |
| Grinding gauge | + | | | 106577 |
| Operator's manual | + | | | 128639 |
| Safety instructions (printed in red) | + | | | 373678 |
| Traction eyelet | | | + | 107668 |
| Case | | | + | 121585 |
| Suspension eyelet | | | + | 097208 |
| Fin set (4 x) | | + | | 1440002 |
| Lubricating grease "S1" | + | | | 0121486 |

Table 7

Ordering original parts and wearing parts

To ensure the correct and fast delivery of original parts and wearing parts:

1. Specify the order number.
2. Enter further order data:
 - Voltage data
 - Quantity
 - Machine type
3. Specify the complete shipping information:
 - Correct address.
 - Desired delivery type (e.g. air mail, courier, express mail, ordinary freight, parcel post)
4. Send the order to the TRUMPF representative office. Refer to the address list at the end of the document for TRUMPF service addresses.